



LX 16/35

ENERGY GENERATION



1600kg Capacity

The strong LX structure, the powerful electric motors and the two lateral cylinders allow a nominal load capacity of 1600 kg with a high residual capacity



ZAPI CONTROLLER

AC technology guarantees more energy efficiency and longer battery charging duration, thus reducing maintenance cost. Furthermore the absence of brushes in the motor and the simpler motor structure increase system reliability.



TILLER AND CONTROLS

Improved tiller with lifting/lowering proportional controls. Fully integrated system with throttle, safety pushbutton, horn, hourmeter, battery status indicator and turtle button.



MANEUVERABILITY

The overall width has the same size than the EuroPallet (800mm) allow the unit to work in narrow spaces and corridors, increase maneuverability and reducing the turning radius.



VISIBILITY

The wide mast and central driving position allow to have a great operator visibility



BATTERY COMPARTMENT

The separate battery compartment allow the installation of high capacity battery (225Ah - 300Ah). The battery inspection is easy and comfortable trough the battery cover with hinges. As option automatic battery refilling system can be supplied as the external high frequency battery charger that can be easilly plugged trough Anderson connector.



EASY MAINTENANCE

Removing the strong cover allow to have the access to electric and hydraulic system as to the motorwheel and stabilizing wheels.

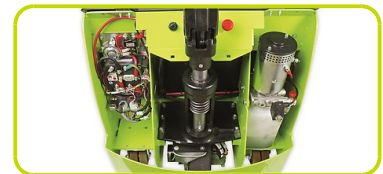

OPERATOR PLATFORM

The LX stacker can be equipped with cushioned stand-on foldable platform very useful for covering medium-sized distances and for intensive application.



Description

1.1 Manufacturer			PR INDUSTRIAL
1.3 Drive			Electric
1.4 Operator type			Pedestrian
1.5 Load capacity	Q	Kg	1600
1.6 Load centre distance	c	mm	600
1.8 Load axle to end forks	x	mm	820
1.9 Wheel base	y	mm	1436

Weights

2.1 Service weight (battery included)		Kg	1090
2.1 Service weight, With platform - battery included		Kg	1120
2.2 Axle load, laden rear		Kg	1685
2.2 Axle load, laden front		Kg	1005
2.3 Axle load, unladen front		Kg	750
2.3 Axle load, unladen rear		Kg	340

Tyres/Chassis

3.1 Tyres: front wheels			RUBBER
3.1 Tyres: stabilizers wheels - Front			POLY.C.
3.1 Tyres: rear wheels			POLY.C.
3.2 Tyre size: Steering wheels - Width		mm	101
3.2 Tyre size: Steering wheels - Diameter		mm	250
3.3 Tyre size: Load rollers - Diameter		mm	82
3.3 Tyre size: Load rollers - Width		mm	70
3.4 Tyre size: stabilizers wheels front - Diameter		mm	100
3.4 Tyre size: stabilizers wheels front - Width		mm	38
3.5 Tyre size: rear wheels - Q.ty (X=driven)		nr	4
3.5 Tyre size: front wheels - Q.ty (X=driven)		nr	1x
3.6 Tread, front	b10	mm	586
3.7 Tread, rear	b11	mm	390

Dimensions

4.2 Height, mast lowered	h1 mm	2265
4.3 Normal free lifting	h2 mm	NOT APPLICABLE
4.4 Lift height	h3 mm	3410
4.5 Height, mast extended	h4 mm	3970
4.6 Initial lift	h5 mm	NOT APPLICABLE
4.9 Height of tiller in drive position min	h14 mm	990
4.9 Height of tiller in drive position max	h14 mm	1390
4.15 Height, lowered	h13 mm	90
4.19 Overall length	l1 mm	1944
4.19 Overall length with lowered platform	l1 mm	2528
4.19 Overall length with raised platform	l1 mm	2068
4.20 Length to face of forks	l2 mm	795
4.20 Length to face of forks with lowered platform	l2 mm	1378
4.20 Length to face of forks with raised platform	l2 mm	919
4.21 Overall width	b1 mm	800
4.22 Fork dimensions - Thickness	s mm	70
4.22 Fork dimensions - Width	e mm	170
4.22 Fork dimensions - Length	l mm	1150
4.24 Fork carriage width	b3 mm	644
4.25 Distance between fork arms	b5 mm	560
4.26 Distance between legs	b4 mm	NOT APPLICABLE
4.32 Ground clearance, centre of wheelbase	m2 mm	20
4.34 Aisle width	Ast mm	2365
4.34 Aisle width with lowered platform	Ast mm	2948
4.34 Aisle width with raised platform	Ast mm	2494
4.35 Turning radius	Wa mm	1613
4.35 Turning radius with lowered platform	Wa mm	2196
4.35 Turning radius with raised platform	Wa mm	1742

Performance data

5.1 Travel speed laden	Km/h	6.0
5.1 Travel speed unladen	Km/h	6.0
5.1 Travel speed laden with platform in lowered position	Km/h	6.0
5.1 Travel speed unladen with platform in lowered position	Km/h	6.0
5.1 Travel speed laden with platform in raised position or with raised forks	Km/h	6.0
5.1 Travel speed unladen with platform in raised position or with raised forks	Km/h	6.0
5.2 Lifting speed laden	m/s (strokes)	0.13
5.2 Lifting speed unladen	m/s (strokes)	0.25
5.3 Lowering speed laden	m/s	0.31
5.3 Lowering speed unladen	m/s	0.38
5.8 Max gradeability laden	%	5
5.8 Max gradeability unladen	%	10
5.10 Service brake		REVERSE CURRENT BRAKING

Electric motors

6.1 Drive motor power	kW	1.2
6.2 Lift motor power	kW	3.2
Battery type		Traction (C5)
6.4 Battery voltage	V	24
6.4 Battery capacity, Min	%	225
6.4 Battery capacity, Max	%	300
6.5 Battery weight, Min	Kg	270
6.5 Battery weight, Max	Kg	270
6.6 Energy consumption according to VDI cycle	kWh/h	1.17
8.4 Sound level at driver's ear	dB(A)	67

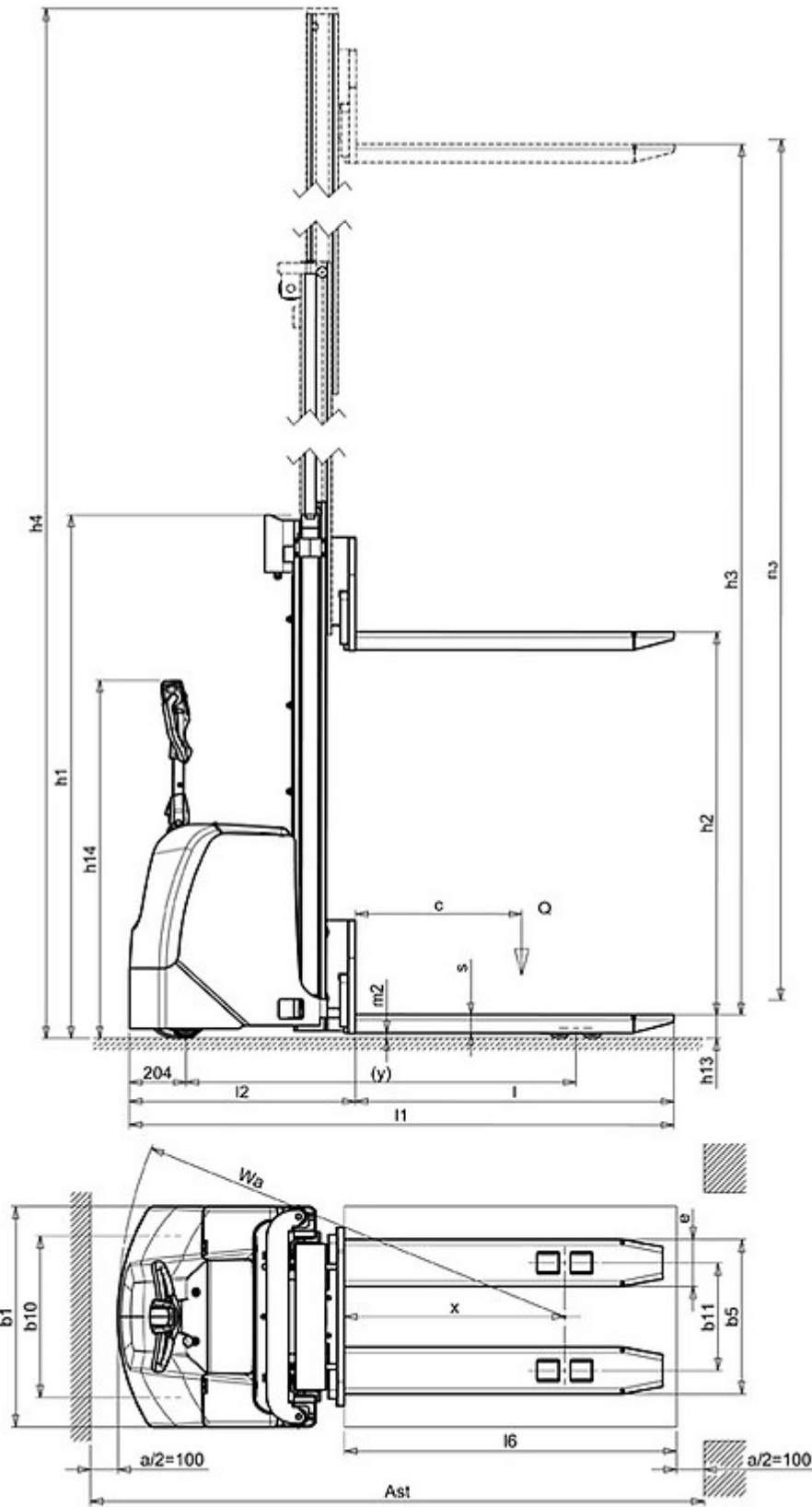

Printed on 25/05/2016 (ID 3111)

©2012 | PR INDUSTRIAL s.r.l. | All rights reserved | Image shown may not reflect actual package. Specifications subject to change without notice | ENERGY GENERATION is registered trademarks of PR INDUSTRIAL s.r.l. Other company, product or service names may be trademarks or service marks of others. RevA (06/2012).