



LX 12/16

# ENERGY GENERATION

## DESIGNED FOR TOP PERFORMANCE



The LX II edition is a strong and reliable partner which bridges the gap between low-duty and heavy duty material handling daily operations. Due to its durability, low maintenance LX is suitable for environments as logistic centers, terminals, production and manufacturing areas. Also the new tiller arm equipped with fork lifting and lowering proportional control improves user-friendliness and maneuverability of the truck.

### ZAPI CONTROLLER

AC technology guarantees more energy efficiency and longer battery charging duration, thus reducing maintenance cost. Furthermore the absence of brushes in the motor and the simpler motor structure increase system reliability.



### TILLER AND CONTROLS

Improved tiller with lifting/lowering proportional controls. Fully integrated system with throttle, safety pushbutton, horn, hourmeter, battery status indicator and turtle button.



## MANEUVERABILITY

The overall width has the same size than the EuroPallet (800mm) allow the unit to work in narrow spaces and corridors, increase maneuverability and reducing the turning radius.



## VISIBILITY

The wide mast and central driving position allow to have a great operator visibility



## BATTERY COMPARTMENT

The separate battery compartment allow the installation of high capacity battery (225Ah - 300Ah). The battery inspection is easy and comfortable trough the battery cover with hinges. As option automatic battery refilling system can be supplied as the external high frequency battery charger that can be easilly plugged trough Anderson connector.



## EASY MAINTENANCE

Removing the strong cover allow to have the access to electric and hydraulic system as to the motorwheel and stabilizing wheels.



## OPERATOR PLATFORM

The LX stacker can be equipped with cushioned stand-on foldable platform very useful for covering medium-sized distances and for intensive application.



## Description

1.1 Manufacturer			PR INDUSTRIAL
1.3 Drive			Electric
1.4 Operator type			Pedestrian
1.5 Load capacity	Q	Kg	1200
1.6 Load centre distance	c	mm	600
1.8 Load axle to end forks	x	mm	780
1.9 Wheel base	y	mm	1373

## Weights

2.1 Service weight (battery included)		Kg	750
2.1 Service weight, With platform - battery included		Kg	780
2.2 Axle load, laden rear		Kg	1190
2.2 Axle load, laden front		Kg	761
2.3 Axle load, unladen front		Kg	540
2.3 Axle load, unladen rear		Kg	210

## Tyres/Chassis

3.1 Tyres: front wheels			RUBBER
3.1 Tyres: stabilizers wheels - Front			POLY.C.
3.1 Tyres: rear wheels			POLY.C.
3.2 Tyre size: Steering wheels - Width		mm	76
3.2 Tyre size: Steering wheels - Diameter		mm	250
3.3 Tyre size: Load rollers - Diameter		mm	82
3.3 Tyre size: Load rollers - Width		mm	70
3.4 Tyre size: stabilizers wheels front - Diameter		mm	100
3.4 Tyre size: stabilizers wheels front - Width		mm	38
3.5 Tyre size: rear wheels - Q.ty (X=driven)		nr	4
3.5 Tyre size: front wheels - Q.ty (X=driven)		nr	1x
3.6 Tread, front	b10	mm	586
3.7 Tread, rear	b11	mm	410

**Dimensions**

4.2 Height, mast lowered	h1 mm	1965
4.3 Normal free lifting	h2 mm	1510
4.4 Lift height	h3 mm	1510
4.5 Height, mast extended	h4 mm	1965
4.6 Initial lift	h5 mm	NOT APPLICABLE
4.9 Height of tiller in drive position min	h14 mm	990
4.9 Height of tiller in drive position max	h14 mm	1390
4.15 Height, lowered	h13 mm	90
4.19 Overall length	l1 mm	1920
4.19 Overall length with lowered platform	l1 mm	2503
4.19 Overall length with raised platform	l1 mm	2043
4.20 Length to face of forks	l2 mm	765
4.20 Length to face of forks with lowered platform	l2 mm	1353
4.20 Length to face of forks with raised platform	l2 mm	893
4.21 Overall width	b1 mm	800
4.22 Fork dimensions - Thickness	s mm	70
4.22 Fork dimensions - Width	e mm	150
4.22 Fork dimensions - Length	l mm	1150
4.24 Fork carriage width	b3 mm	650
4.25 Distance between fork arms	b5 mm	560
4.26 Distance between legs	b4 mm	NOT APPLICABLE
4.32 Ground clearance, centre of wheelbase	m2 mm	20
4.34 Aisle width	Ast mm	2330
4.34 Aisle width with lowered platform	Ast mm	2913
4.34 Aisle width with raised platform	Ast mm	2450
4.35 Turning radius	Wa mm	1550
4.35 Turning radius with lowered platform	Wa mm	2133
4.35 Turning radius with raised platform	Wa mm	1670

**Performance data**

5.1 Travel speed laden	Km/h	6.0
5.1 Travel speed unladen	Km/h	6.0
5.1 Travel speed laden with platform in lowered position	Km/h	6.0
5.1 Travel speed unladen with platform in lowered position	Km/h	6.0
5.1 Travel speed laden with platform in raised position or with raised forks	Km/h	6.0
5.1 Travel speed unladen with platform in raised position or with raised forks	Km/h	6.0
5.2 Lifting speed laden	m/s (strokes)	0.15
5.2 Lifting speed unladen	m/s (strokes)	0.28
5.3 Lowering speed laden	m/s	0.31
5.3 Lowering speed unladen	m/s	0.16
5.8 Max gradeability laden	%	5
5.8 Max gradeability unladen	%	10

## Electric motors

6.1 Drive motor power	kW	1.2
6.2 Lift motor power	kW	2.2
Battery type		Traction (C5)
6.4 Battery voltage	V	24
6.4 Battery capacity, Min	%	225
6.4 Battery capacity, Max	%	300
6.5 Battery weight, Min	Kg	270
6.5 Battery weight, Max	Kg	270
6.6 Energy consumption according to VDI cycle	kWh/h	1.08
8.4 Sound level at driver's ear	dB(A)	67

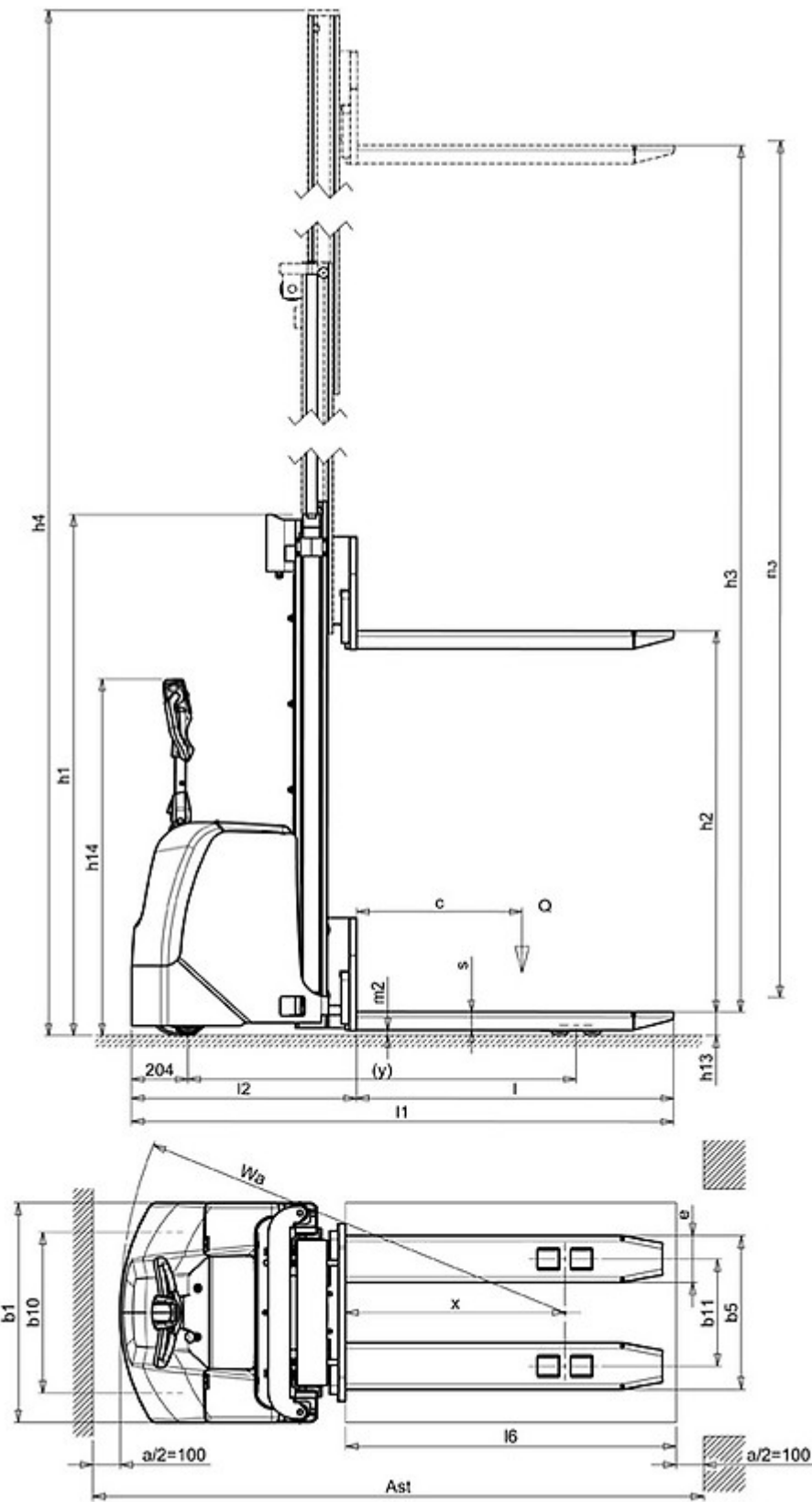

Printed on 25/05/2016 (ID 3112)

©2012 | PR INDUSTRIAL s.r.l. | All rights reserved | Image shown may not reflect actual package. Specifications subject to change without notice | ENERGY GENERATION is registered trademarks of PR INDUSTRIAL s.r.l. Other company, product or service names may be trademarks or service marks of others. RevA (06/2012).